

## TECHNICAL SPECIFICATION - TS21

LOW CARBON ERW STEEL TUBING FOR GENERAL APPLICATIONS

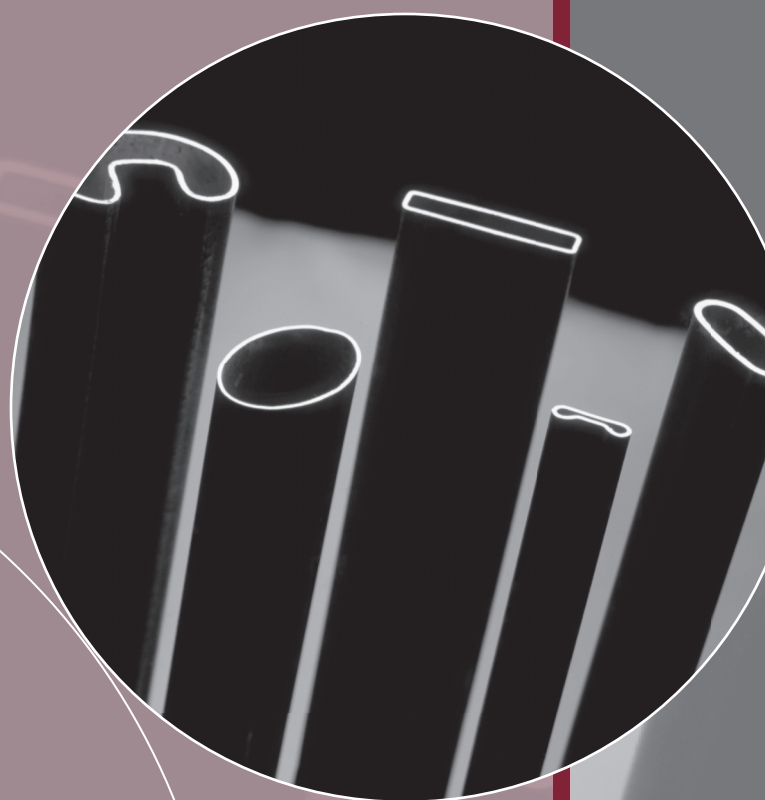

		PAGE
<b>1.0</b>	Scope	1
<b>2.0</b>	References	1
<b>3.0</b>	Definitions	1
<b>4.0</b>	Designation	1
<b>5.0</b>	Information to be Supplied by the Purchaser	2
<b>6.0</b>	Requirements	2
<b>6.1</b>	Tube Condition	2
<b>6.2</b>	Chemical Composition	2
<b>6.3</b>	Mechanical Properties	3
<b>6.4</b>	Surface Finish	4
<b>6.5</b>	Tube Dimensions and Wall Thickness	5
<b>6.6</b>	Length	7
<b>6.7</b>	Height of Weld Upset	9
<b>6.8</b>	End Condition	9
<b>6.9</b>	End Welds (Cross Welds)	10
<b>6.10</b>	Straightness	10
<b>6.11</b>	Non-Circular Tube - Other Features	11
<b>6.12</b>	Rust Prevention	12
<b>6.13</b>	Packaging	13
<b>7.0</b>	Control	13

## 1.0 Scope

This specification covers the technical requirements for the production and supply of low carbon ERW (electric resistance welded) steel tubing supplied in the As Formed Condition with a commercial quality or bright quality surface finish and with the internal weld upset (fin) not removed. This product is intended for use in furniture and other general applications requiring ductile tubing and is generally denoted as EzyForm™.

- Note:
1. Tubing in the As Formed condition with a black surface finish and produced from black (hot-rolled) strip for general applications, is covered in;  
TS11 Black (Hot Rolled) ERW Steel Tubing.
  2. Tubing in other steel grades, which is supplied with specified tensile properties or specific chemistries for structural and mechanical purposes, is covered in;  
TS22 ERW Steel Tubing with Specified Mechanical Properties (Hi-Lite®).
  3. Tubing supplied in the As Formed condition with special requirements in relation to fin cutting, dimensional tolerances, mechanical tests and/or other additional requirements, is covered in;  
TS31 Low Carbon ERW Steel Tubing with Special Requirements.
  4. Tubing in the As formed condition intended for use in fluid carrying applications which require an eddy current test is covered in;  
TS41 Low Carbon ERW Steel Tubing for Fluid Carrying Applications.

## 2.0 References

ATM Precision Tube Customer Information Handbook – Standard Terminology.

## 3.0 Definitions

Terms used in this specification are defined in the ATM Precision Tube Customer Information Handbook Standard Terminology.

## 4.0 Designation

Tubing ordered to this specification shall be designated as:

- (i) TS21 EzyForm™ Commercial for tube supplied with a Commercial Quality (CQ) surface finish, or
- (ii) TS21 EzyForm™ Bright for tube supplied with a Bright Quality (BQ) surface finish.

## 5.0 Information to be Supplied by the Purchaser:

The purchaser should supply the following information at the time of an enquiry and/or order.

- (a) Dimensions of cross section (diameter/non circular size and wall thickness).
- (b) Length required (in mm) and type (ML, NSML, CL) - refer to clause 6.6.
- (c) Designation ie. TS21 EzyForm™ .
- (d) Surface finish ie Commercial Quality (CQ) or Bright Quality (BQ) - refer to clause 6.4.
- (e) Quantity and delivery instructions.

## 6.0 Requirements

### 6.1 Tube Condition

Tubing shall be supplied in the As Formed condition ie as produced ex the weldmill.

### 6.2 Chemical Composition

The cast analysis of the steel used shall conform to the following:

TABLE 1 : TS21 STANDARD CHEMISTRY		
	Guaranteed Maximum (%)	Typical (%)
Carbon (C)	0.10	0.060
Phosphorous (P)	0.040	0.015
Manganese (Mn)	0.45	0.20
Silicon (Si)	-	0.0050
Sulphur (S)	0.040	0.010
Alumium (Al)	-	0.035

- Note:
1. The selection of the actual steel grade shall be at the option of OneSteel unless otherwise negotiated and specified on the order.
  2. For special applications, alternative chemical compositions can be negotiated in some cases, and would be supplied to TS22 HiLite®.

## 6.3 Mechanical Properties

### 6.3.1 Tensile Test

Tubing in the As-Formed condition shall conform to the following tensile properties:

**TABLE 2 : MECHANICAL PROPERTIES**

D/t Ratio	< 15	$15 \leq D/t < 25$	$25 \leq D/t < 35$	$\leq 35$
Yield Strength MPa (min)	300	275	250	200
Tensile Strength MPa (min)	310	300	290	280
Elongation % (min)	15	20	25	30

where: D = outside diameter or equivalent round  
t = nominal wall thickness

Note: 1. For special applications, alternative mechanical properties can be negotiated in some cases, and would be supplied to TS22 HiLite®.

### 6.3.2 Flare Test

Both circular and non-circular tube shall be capable, with suitable end preparation, of being expanded over a cone or pyramid shaped drift expander until metal failure with no evidence of radial fracture of the weld zone, ie fracture of the weld zone along a radial line from the tube centre to the outside surface is not acceptable.

A ductile/shear (45°) fracture of the weld zone or fracture of the parent metal is acceptable.

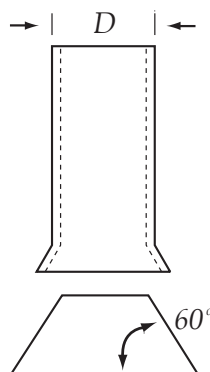

### 6.3.3 Flattening Tests

Circular tube shall be capable of being flattened without cracking between two parallel plane surfaces with the weld located at 90° and 0° to the direction of flattening until the distance between the surfaces is half the nominal outside diameter of the tube.

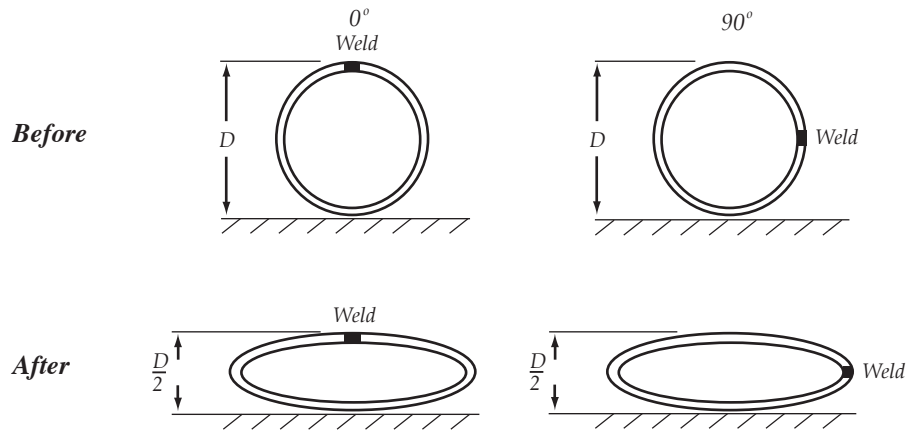

Note: 1. These tests are not applicable to non-circular tube.

### 6.4 Surface Finish

Tube shall be supplied with a commercial quality (CQ) surface finish or a bright quality (BQ) surface finish, the requirements of which are:

**TABLE 3 : CQ AND BQ SURFACE FINISH - EZYFORM™**

Feature	Bright Quality (BQ) <sup>(1)</sup>	Commercial Quality (CQ)
Coil Break (Creases in Strip)	The surface shall be free of visual evidence of coil break.	Coil break up to 0.10 mm deep shall not be cause for rejection.
Pitting	Isolated pits not exceeding 0.05 mm deep shall not be cause for rejection.	Isolated pits not exceeding 0.15 mm deep shall not be cause for rejection.
O.D. Scarfing	The external weld flash shall be cleanly removed to produce a smooth surface free of tool chatter marks.	The external weld flash shall be cleanly removed. Tool chatter marks up to 0.10 mm deep shall not be cause for rejection.
Other Surface Marking <sup>(2)</sup>	Surface marking up to 0.05 mm deep shall not be cause for rejection. <sup>(3)</sup>	Surface marking up to 0.10 mm deep shall not be cause for rejection. <sup>(3)</sup>

- Note:
- Bright quality is suitable for applications where the surface finish is an important feature (eg. for subsequent plating). The amount of polishing required prior to plating will depend upon the standard of finish required.
  - Other surface marking includes longitudinal roll marks, chop marks (quarter moon shaped roll marks), indentations due to metal pick up on weldmill tooling, scratches, reeler straightening marks, handling marks and weld burn (low frequency welding only).
  - Notwithstanding the above table of possible defects, the overall appearance of the tube shall be consistent with good workmanship.

## 6.5 Tube Dimensions and Wall Thickness

### 6.5.1 Outside Diameter - Circular Tube

Circular tube shall be supplied to the following dimensional tolerances:

TABLE 4 : OUTSIDE DIMENSIONAL TOLERANCES	
Outside Diameter, D (mm)	Maximum Permissible Variation in Outside Diameter, v (mm)
$D \leq 16$	$\pm 0.10$
$16 < D \leq 25$	$\pm 0.15$
$25 < D \leq 50$	$\pm 0.20$
$50 < D \leq 75$	$\pm 0.25$
$75 < D \leq 100$	$\pm 0.30$
$100 < D \leq 125$	$\pm 0.35$

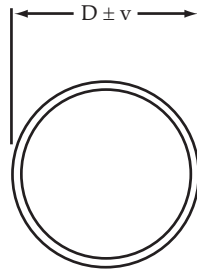

- Note:
1. If the wall thickness is less than 2.5% of the diameter, the above extreme tolerances shall be increased to 1.5 times the values shown.
  2. Due to the possible distortion of the tube on cutting, the outside diameter tolerance does not apply for a distance of 25mm from the end of mill lengths (MLs) or non standard mill lengths (NSMLs) ie. on tube cut to length on the weldmill - refer to clause.
  3. For special applications, tighter tolerances can be negotiated in some cases and would be supplied to TS31 Ezyform™.
  4. As Formed ERW tube may change shape near the end of the tube due to the effects of welding and cutting when the tube is cut to the final required length.

## 6.5.2 Outside Dimensions - Non-Circular Tube

TABLE 5 : OUTSIDE DIMENSIONAL TOLERANCES - NON CIRCULAR TUBE				
Dimension, a (mm)	Maximum Permissible Variation in Diameter, v (mm)			
	Squares	Rectangles Long Side	Other Shapes Long Side      Short Side	
$a \leq 20$	$\pm 0.15$	$\pm 0.15$	$\pm 0.15$	$\pm 0.30$
$20 < a \leq 40$	$\pm 0.20$	$\pm 0.20$	$\pm 0.20$	$\pm 0.40$
$40 < a \leq 60$	$\pm 0.25$	$\pm 0.25$	$\pm 0.25$	$\pm 0.50$
$60 < a \leq 80$	$\pm 0.30$	$\pm 0.30$	$\pm 0.30$	$\pm 0.60$
$80 < a \leq 100$	$\pm 0.35$	$\pm 0.35$	$\pm 0.35$	$\pm 0.70$
$100 < a \leq 120$	$\pm 0.40$	$\pm 0.40$	$\pm 0.40$	$\pm 0.80$

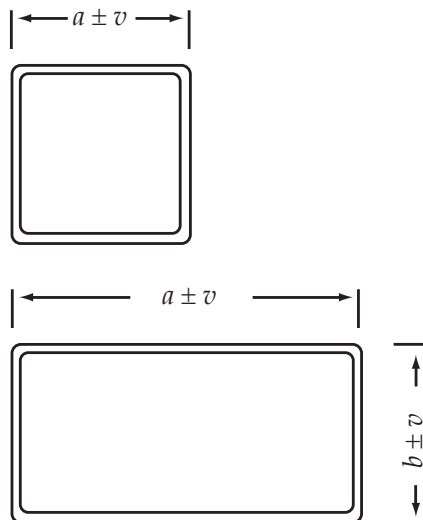

- Note:
1. In the case of rectangles the tolerance shown for the long side shall also be applied to the short side.  
(eg. the tolerances for 5025 rectangular tube shall be  $50.0 \pm 0.25\text{mm} \times 25.0 \pm 0.25\text{mm}$ ).
  2. Due to the possible distortion of the tube on cutting, the tolerance shown does not apply for a distance of 25mm from the end of mill lengths (MLs) or non standard mill lengths (NSMLs) i.e. on tube cut to length on the weldmill - refer to clause 6.8.
  3. For special applications, tighter tolerances can be negotiated in some cases and would be supplied to TS31 Ezyform™.
  4. As Formed ERW tube may change shape near the end of the tube due to the effects of welding and cutting when the tube is cut to the final required length.

### 6.5.3 Wall Thickness

Tubing shall be supplied to the wall thickness tolerances as set out below:

TABLE 6 : WALL THICKNESS TOLERANCES	
Wall Thickness, $t$ (mm)	Maximum Permissible Variation in Wall Thickness, $v$ (mm)
$t \leq 1.0$	$\pm 0.10$
$1.0 < t \leq 1.6$	$\pm 0.15$
$1.6 < t \leq 2.0$	$\pm 0.20$
$2.0 < t \leq 3.0$	$\pm 0.25$
$3.0 < t \leq 4.0$	$\pm 0.30$
$4.0 < t \leq 5.0$	$\pm 0.35$
$5.0 < t \leq 6.0$	$\pm 0.40$

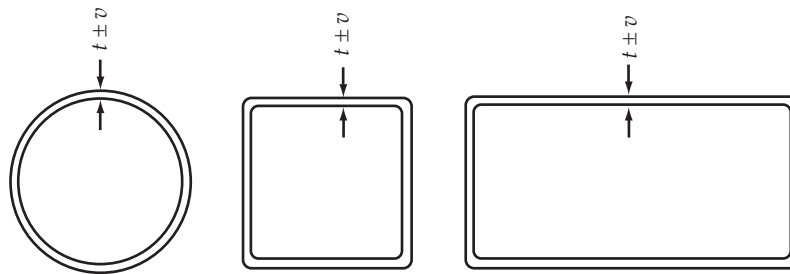

- Note:
1. As localised thickening may occur, the above plus variations do not apply to the weld area as indicated by the width of the heat affected zone.
  2. For special applications, tighter tolerances can be negotiated in some case and would be supplied to TS31 Ezyform™.

### 6.6 Length

#### 6.6.1 Mill Lengths

Unless otherwise specified on the order, tubing shall be supplied in mill lengths (ML) of 6100 mm (6.1 metres), or by arrangement, tubing can be supplied ex the weldmill as a non-standard mill length (NSML) within the length range 4000 to 8000 mm eg. 5850 mm NSML. In both cases, a length tolerance of plus 50 mm minus Nil shall apply.

### 6.6.2 Cut Lengths

By arrangement, tubing can be supplied as cut lengths (CL). The tolerances applicable to length are:

TABLE 7 : CUT LENGTH TOLERANCES	
Cut Length, CL (mm)	Max. Permissible Variation in Cut Length, v (mm)
CL ≤ 1000	± 0.10
1000 < CL ≤ 2000	± 0.15
2000 < CL ≤ 4000	± 0.20
4000 < CL ≤ 6000	± 0.25
CL > 6000	± 0.30

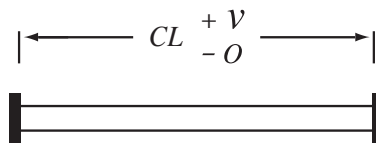

Note: 1. The tube length shall be taken to be the measured distance between two parallel plates in contact with each end of the tube. This could vary from the overall length measured along the outside of the tube using a micrometer, vernier or similar device due to the tolerance for end squareness.

### 6.6.3 End Squareness

End squareness shall be expressed as the maximum deviation that can be measured between the end of the tube and a straight edge in contact with the end of the tube and at right angles to the tube axis. The maximum allowable out of squareness shall be 0.05 mm per 10 mm of O.D. (equivalent to 0.3°). End squareness shall apply only to cut lengths up to 1000 mm.

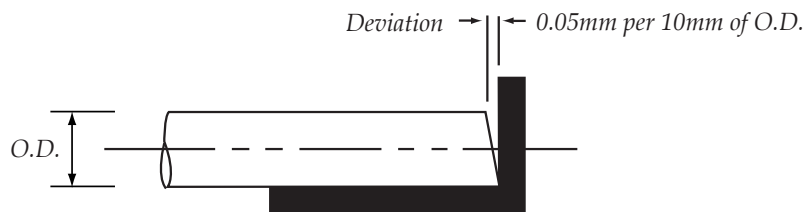

## 6.7 Height of Weld Upset

The external weld upset shall be removed completely ie. flush with the outside surface of the tube. The internal weld upset or fin is not normally removed and the height may measure up to 1.0 mm or 50% of the nominal wall thickness whichever is the greater. This condition is designated Normal Fin (NF).

By arrangement, tube with other than Normal Fin conditions may be supplied. This tube would be designated as TS31.

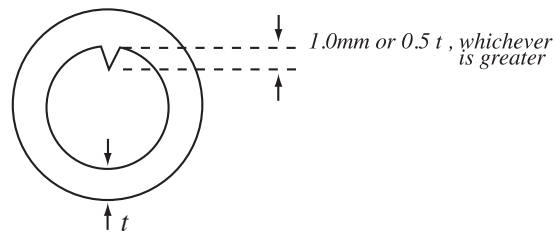

## 6.8 End Condition

### 6.8.1 Mill Lengths

Tube shall be supplied with shear or saw cut mill ends that may have a small shear dimple or burrs.

### 6.8.2 Cut Lengths

Cut lengths can be supplied with the following specific end conditions:

#### (a) As Cut

Tube ends will be as cut by shear, saw, laser or lathe and some cutting burr could remain.

#### (b) Deburred

Safe to handle and no dimensional evidence of burr on the outside or inside of the tube. The aim is to completely remove the external and internal burr with minimum stock removal. Unless otherwise specified, there may be evidence of a burr on the end face. Tool chatter is to be avoided but shall not be cause for rejection (workmanship).

#### (c) Chamfer

The tube end shall be tool cut on the external and/or internal surface of the tube end to the following dimensions (unless otherwise negotiated and specified on the order).

Angle of Chamfer =  $30^{\circ} \pm 5^{\circ}$

Min. Length of Chamfer = 0.10 mm

Max. Length of Chamfer = 2.10 mm

Stock removal - at least 50% of nominal wall thickness shall remain after internal and/or external chamfering. Tool chatter - shall be avoided but shall not be cause for rejection (workmanship).

- Note:
1. Cut lengths specified as Deburred may be supplied in the Chamfered condition.
  2. Other specific end finishing requirements can be supplied subject to enquiry.

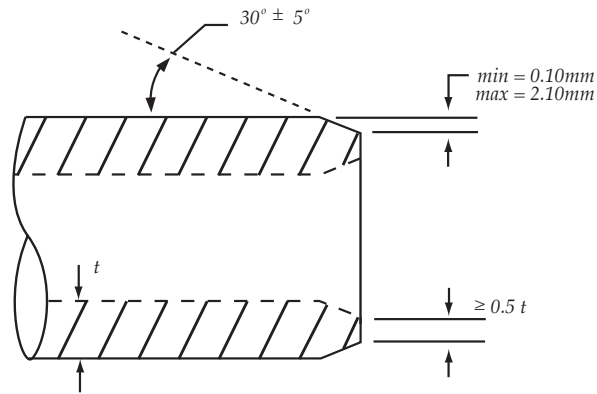

## 6.9 End Welds (Cross Welds)

Tubes containing the cross welds used to join the end of one coil of strip to the next shall not be included in the consignment.

## 6.10 Straightness

For lengths greater than or equal to 1000 mm the straightness tolerance shall be as shown in the table below, which assumes the tube to be bent in a constant radius, measured against a straight edge.

For lengths less than 1000 mm the straightness tolerance shall be 1.0 mm maximum deviation.

**TABLE 8 : STRAIGHTNESS TOLERANCES**

Length (mm)	1,000	2,000	3,000	4,000	5,000	6,000	6,100	7,000	8,000
Tolerance (mm)	1.0	1.1	2.5	4.4	6.9	10.0	10.3	13.6	17.8

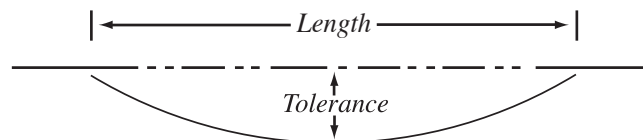

By arrangement, tube with other straightness tolerances can be supplied in some cases.

## 6.11 Non-Circular Tube - Other Features

### 6.11.1 Corner Radii

Corner radii differ for each size and wall thickness combination. Typical corner radii information can be supplied on request.

### 6.11.2 Weldline Location

Due to the configuration of the weldmill rolls, the weldline will normally be equidistant from the opposite corners ie. the weldline will be on or adjacent to a corner in the case of squares and on the longer face in the case of rectangles, ovals and flat sided ovals.

No action is normally taken to control the exact location of the weldline. However, where weldline location is a critical feature this should be the subject of an enquiry and would be supplied to TS31.

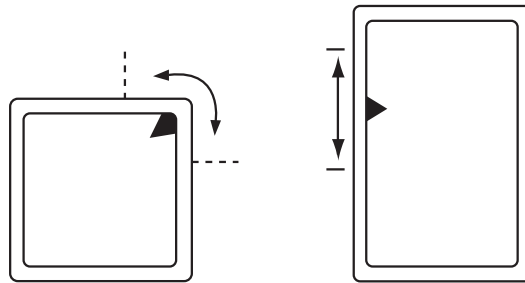

### 6.11.3 Twist

The tolerances for twist of non-circular tubing are shown in the table below:

TABLE 9 : TWIST TOLERANCE	
Largest Dimension, a (mm)	Twist Tolerance in 1 metre, v (mm)
$a \leq 12.7$	0.9
$12.7 < a \leq 38.1$	1.4
$38.1 < a \leq 63.5$	1.7
$63.5 < a \leq 101.6$	2.1

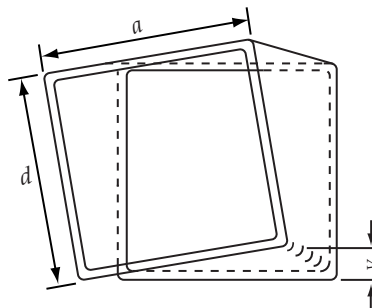

### 6.11.4 Squareness - Square and Rectangular Tube

Maximum out of square of adjacent sides shall be 0.10 mm in 10 mm face width (equivalent to 0.6°).

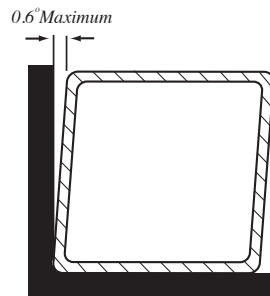

### 6.11.5 Flatness - Square, Rectangular and Flat Sided Oval Tube

The actual dimensional variation across any face shall not exceed half of the total outside dimensional tolerance as set out in clause 6.5.2.

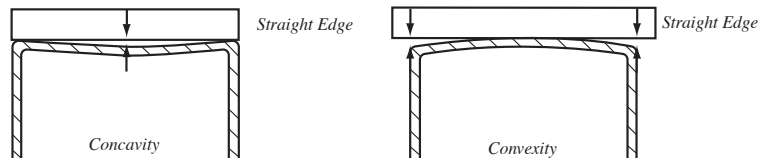

## 6.12 Rust Prevention

### 6.12.1 Standard Rust Prevention

The tube shall be coated with a light, readily removable, temporary rust preventative, designed to withstand corrosion when stored in normal conditions under cover for at least three months from time of delivery.

### 6.12.2 No Added Oil

By arrangement, tube can be supplied with no temporary rust preventative added.

- Note:
1. The possibility of corrosion of tube in this state will be greater, and instances of corrosion shall not be cause for rejection.
  2. Residual oils from the manufacturing process may be present.

## 6.13 Packaging

Standard packaging for mill lengths and some cut lengths is batten-strapped, rectangular or hexagonal packs.

- Note:
1. By arrangement, other packaging options may be available. For example, stillages may be used to supply cut lengths, and large diameter tubing may be supplied in crates.
  2. Standard pack sizes for mill lengths are described in the Dimensions and Properties section of the ATM Precision Tube Customer Information Handbook. Different pack sizes shall be the subject of agreement between the customer and the supplier.

## 7.0 Control

This specification is not to be reproduced without the authority of the originator. Holders of this specification should determine its validity prior to use.

## Technical specifications are also available for the following Precision Tubing products:

- TS 11** EzyForm™ - Hot rolled, low carbon ERW steel tubing for general applications
- TS 21** EzyForm™ - Low carbon ERW steel tubing for general applications
- TS 22** Hi-Lite® - ERW steel tubing with specified mechanical properties
- TS 23** VHS - Mild carbon heat treated ultra high strength ERW steel tubing
- TS 28** Hi-Form® - Low carbon ERW Aluminised steel tubing for use in automotive exhaust systems
- TS 30** GALVATUBE™ - Premium low carbon ERW steel tubing for general applications
- TS 31** EzyForm™ - Low carbon ERW steel tubing with special requirements
- TS 40** ReadiTube® - Low carbon galvanised ERW steel tubing for general applications
- TS 41** EzyForm™ - Low carbon ERW steel tubing for fluid carrying applications
- TS 50** Tubecolor® - Premium powder coated ERW steel tubing
- TS 60** Painted RT™ - Powder coated ERW steel tubing

OneSteel has a range of other Technical Specifications for products and/or applications not listed above. Please contact OneSteel Direct for further Information or visit our website [www.onesteel.com](http://www.onesteel.com)



## ONESTEEL DIRECT

Freecall 1800 178 335

Website [www.onesteel.com](http://www.onesteel.com)

Freefax 1800 101 141

Email [onesteeldirect@onesteel.com](mailto:onesteeldirect@onesteel.com)

This publication has been prepared by OneSteel, (OneSteel Trading Pty Limited ABN 50 007 519 646). Please note that the specifications and technical data are subject to change without notice and to ensure accuracy users of this publication are requested to check the information to satisfy themselves and not to rely on the information without first doing so. Unless required by law the company cannot accept any responsibility for any loss, damage or consequence resulting from the use of this publication. Photographs shown are representative only of typical applications, current at November 2010. This brochure is not an offer to trade and shall not form any part of the trading terms in any transaction. Issue 7 November 2010. Copyright 2010. OneSteel Trading Pty Limited ABN 50 007 519 646 Registered Trademarks: Tubecolor<sup>®</sup>, Hi-Form<sup>®</sup>, EzyForm<sup>™</sup> and GALVATUBE<sup>™</sup>. DuraGal<sup>®</sup> is a registered Trademark of Australian Tube Mills Pty Limited ACN 123 160 172. SJ0076.

**DISTRIBUTED BY**