

The company that published this work is now in a joint venture company named **Australian Tube Mills**. For technical support or sale enquiries please contact **Australian Tube Mills**.

**onesteel**

## DURAGAL® BUILDING SYSTEMS CHICKEN SHED

The DuraGal® Building Systems Broiler Chicken Shed brings to the market a system that offers:

- A light weight, structurally efficient shed constructed from high strength DuraGal® RHS.
- A cost effective coating system. The in-line hot dip galvanized external coating and internal paint coating system applied to DuraGal® RHS provides a product ready for use.
- A range of pre-engineered sheds.
- Proprietary fittings allow fast and efficient assembly.
- The closed DuraGal® RHS frame:
  - Allows easy washing down of the shed interior reducing the risk of dust accumulating and the chance of disease propagation, and
  - Offers streamlined air flow reducing running costs
- A frame system that can accommodate your choice of:
  - Cladding and insulation
  - Environment control systems
  - Feed systems
  - Bay spacing (3.6m is standard and best suited for equipment suspension)



**FURTHER INFORMATION: CONTACT ONESTEEL DIRECT**

**FREECALL: 1800 178 335 WEBSITE: WWW.ONESTEEL.COM FREEFAX: 1800 101 141 EMAIL: ONESTEELDIRECT@ONESTEEL.COM**

## DURAGAL® BUILDING SYSTEMS CHICKEN SHED

### ADVANTAGES OF THE DURAGAL® BUILDING SYSTEMS CHICKEN SHED

- Material pre cut and delivered direct to site as a flat pack, ready to install.
- No bridging or sag rods.
- Telescopic knee and apex fittings.
- Reduced edges minimise the chance of vermin perching and nesting in the shed.
- No protruding fasteners.
- Easy & quick to erect.
- No re-entrant surfaces minimising the potential for trapping dust and moisture.
- Visually pleasing clean lines.
- Simple Purlin and Girt fixing.
- Self drilling screws allow speedier assembly.
- Easily cleaned
- No welding and no fiddly, time consuming bolted connections.

### SIZE RANGE:

- Up to 60ft/18m span

### DURAGAL® RHS SIZES:

- 150x50 Columns & Rafters
- 100x50/75x50 Purlins.

### SHED IS ADAPTABLE TO OTHER USES:

- Poultry, Eggs, Pigs, Machinery, Hay Sheds etc.

### STANDARD DURAGAL® PORTAL - QUICK AND EASY ASSEMBLY

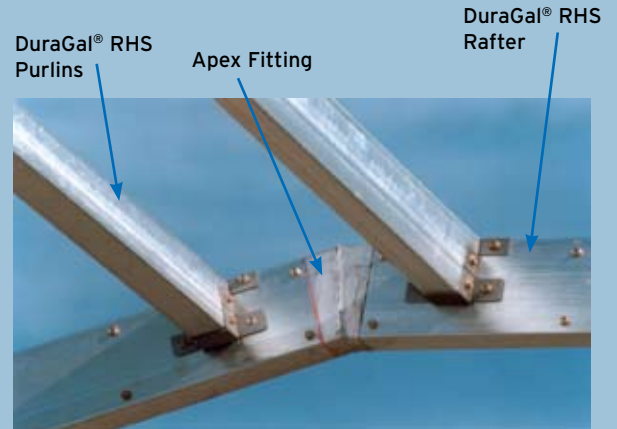
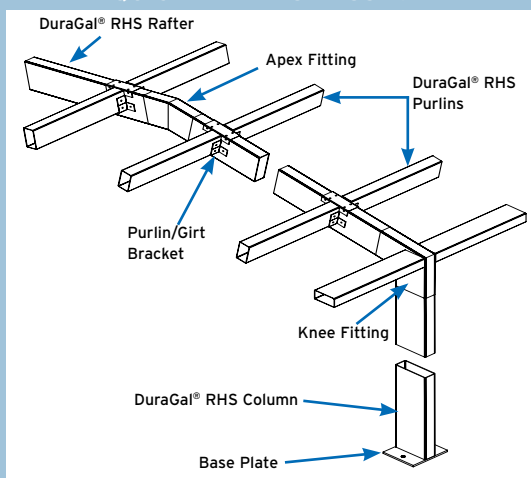

SIMPLE APEX FITTINGS

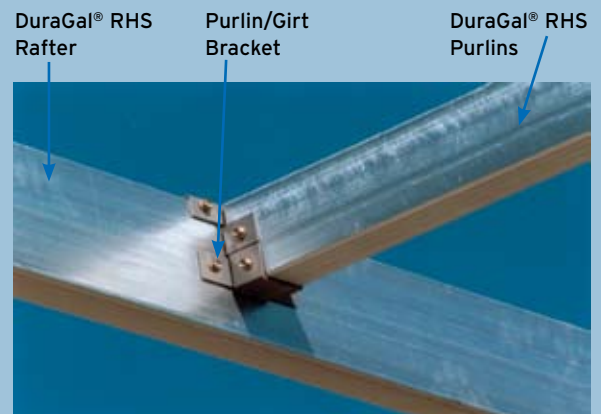

FAST AND EASY PURLIN & GIRT FIXING

### FURTHER INFORMATION: CONTACT ONESTEEL DIRECT

Freecall 1800 178 335

Freefax 1800 101 141

Email [onesteeldirect@onesteel.com](mailto:onesteeldirect@onesteel.com)

Website [www.onesteel.com](http://www.onesteel.com)

### DISTRIBUTED BY: